

Product Datasheet

24W/24V Industrial DIN Rail Power Supply

(SUN-DP24-24)



SUN-DP24-24 è un alimentatore da 24W per guida DIN conforme agli standard industriali tedeschi. È adatto per l'installazione su guide TS-35/7,5 o TS-35/15, utilizza un ingresso da 90VAC a 264VAC ed è conforme alla norma EN61000-3-2 sulle specifiche di corrente armonica specificate dall'Unione Europea.

SUN-DP24-24 adotta un design a guscio metallico per migliorare la dissipazione del calore. L'efficienza di lavoro è pari all'89% e il prodotto può funzionare a una temperatura ambiente compresa tra -40 e 70 gradi in condizioni di circolazione dell'aria. La funzione di protezione da sovraccarico in modalità a corrente costante, adatta a una varietà di applicazioni con carichi induttivi o capacitivi, le funzioni di protezione complete e la conformità alle certificazioni pertinenti per le apparecchiature di controllo industriale ne fanno una soluzione di alimentazione molto competitiva per le applicazioni industriali.

FEATURE

- Meet EMC Standard
- 100% full load aging test
- Power Input: AC90-264V
- Wide operation temperature range: -40°C-70°C
- High efficiency, long life time and high reliability
- Support production for short circuit/over current/over voltage

APPLICATION

- Industrial Control System
- Semiconductor fabrication equipment
- Factory automation
- Electro-mechanical apparatus

TECHNICAL SPECIFICATION

Model	SUN-DP24-24
Output	
Group of Output	1
DC Voltage	24VDC
Output Voltage Factory Setting	24.00-24.2VDC (Vin: 220VAC / Load: 0A)
Output Rated Current	1.0A
Output Current Range	0-1.0A
Rated Output Power	24W
Total Peak Output Power	36W (sustainable time 10S/220VAC)
Peak Output Current	1.5A (sustainable time 10S/220VAC)
Ripple Noise	Peak-to-peak value $\leq 100\text{mV}$. (Measurement method: The terminal should be connected in parallel with 0.1uF and 47uF capacitors, and the

	measurement should be performed at a bandwidth of 20MHz)
Output Voltage Range	22.5-28VDC
Stabilized Voltage Precision	±1% (@ 90-264VAC input, 100% load)
Line Regulation	±0.5% (@ 90-264VAC input, 100% load)
Load Regulation	±1% (@90-264VAC input, 0-100% load)
Output Start Time	<3S @115VAC,<1.6S@230VAC (100% load)
Output Hold Time	>20ms @230VAC (100% load)
Voltage Overshoot	≤5.0%
Input	
Input Voltage Range	90-264VAC
Input Rated Voltage Range	100-240VAC
Frequency Range	47Hz-63Hz
Rated Frequency	50Hz/60Hz
Starting Voltage	90VAC
Efficiency	>85.0% @115VAC, >84.0% @ 230VAC
Input Current	<0.60A @115VAC, <0.30A @ 230VAC
Start Inrush Current	<60A @ 230VAC
Power Factor	PF>0.6 (at full load)
Protection	
Output Over Power	28.8-36W Swing machine (Testing method: Increase the output current until enabling the protection. Protection mode:Swing machine, Self-recovery after over-power released.)
Output Over Voltage	28-30V Swing machine (Short circuit the Pin1-2 of U8, swing machine. Output recovery to normal after removing the short circuit) Note: Do not use external voltage.
Output Over Current	1.2-1.5A Swing machine (Testing method: Increase the output current until enabling the protection. Protection mode:Swing machine, Self-recovery after over-current released.)

Output Short Circuit	Use a copper wire with a sufficient cross-sectional area and a length of 15cm±5cm to directly short-circuit at the power output port, which can be short-circuited for a long time, and can be automatically restored after the short-circuit is eliminated.
Operation Environment	
Operation TEMP / Humidity	-40°C-70°C, 20%-95%RH No condensing
Storage TEMP / Humidity	-40°C-85°C, 10%-95%RH No condensing
Temperature Coefficient	±0.03%/°C (0-50°C)
Vibration	Frequency range 10-500Hz, acceleration 2G, each sweep cycle 10min. 6 sweep cycles along the X, Y, and Z axes
Impact	Acceleration 20G, duration 11ms, 3 shocks along X, Y, and Z axis each
Altitude	2000m
Safety and Electromagnetic Compatibility Standard	
Security Standard	GB4943/EN62368-1 <input checked="" type="checkbox"/> Reference <input type="checkbox"/> Certification
Dielectric Strength	Input—Output: 3KVAC/10mA, Input--Case:1.5KVAC/10mA Output---Case: 0.5KVDC/10mA , Time for each testing is 1min.
Ground Test	Test conditions: 32A/2 minutes, Ground impedance: <0.1 ohms.
leakage Current	Input to ground ≤3.5mA, Input to output ≤0.25mA (Input 264VAC, Frequency 63Hz)
Insulation Resistance	Input-Output: 10M ohms
Conducted Disturbance	EN55022, EN55024, FCC PART 15 Class B
Radiated Interference	EN55022, EN55024, FCC PART 15 Class B
Harmaonic Current	EN61000-3-2 Class D
Conducted Disturbance	EN61000-4-6 Level 3
Radiation Harassment	EN61000-4-3 Level 3 Class B
Power Frequency Harassment	EN61000-4-8 Level 3
Static Harassment	EN61000-4-2 Level 4 Class B

fast Burst	EN61000-4-4 Level 4 Class B
Lightning Strike (Surge)	EN61000-4-5 Level 4 Class B
interrupted Fall	EN61000-4-11
Others	
Dimension	82.5*103*23mm

DIMENSION

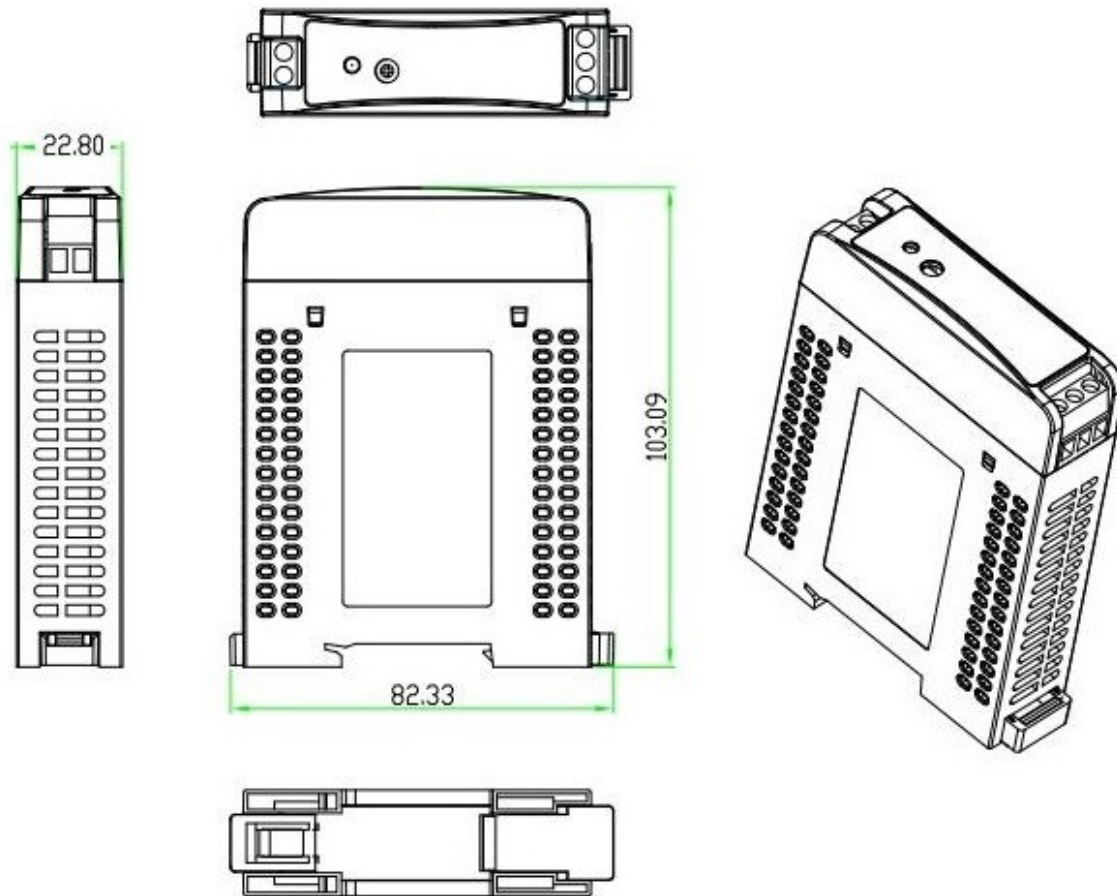

SUNELL ITALIA STARK SOLUTION

Via 3° Strada n°36 Zona Industriale 95121 Catania (CT)

info@sunellitalia.net